

# COBRA™ RODS

## Product Overview

Cobra™ Rods protect utility poles against strength loss caused by internal decay, fungi, and insects. Cobra™ Rods, the first patented water diffusible glass co-biocide internal treatment, migrate within the pole, both vertically and horizontally, from point of application through mass flow and diffusion. Cobra™ Rods deliver the highest concentration and potency of borates and copper to provide the best performance and efficacy for internal treatment and protection of wood substrates. Cobra™ Rods have a very favorable environmental profile and are a general use pesticide that may be used with all species and original treatments of wood. Cobra™ Rods can be applied at load rates depending on age, size, condition, and the environment of the pole.



## Technical Summary

(including 3rd party data and research)

**Cobra™ Rods are manufactured in a variety of sizes, allowing utilities to maximize loading within new or existing borings.**

- Cobra™ Rods ½"x4" (Genics' product number 20009), pail of 500
- Cobra™ Rods ¾"x3" (Genics' product number 20011), pail of 250
- Cobra™ Rods 1/3"x 2 5/8" (Genics' product number 20020), pail of 1,000

# Cobra™ Rods – Composition and Chemistry

## Active ingredients:

Disodium Octaborate

Tetrahydrate 90.6%

Copper Hydroxide 2.9%

Boric Acid 4.7%

**TOTAL ACTIVES 98.2%**

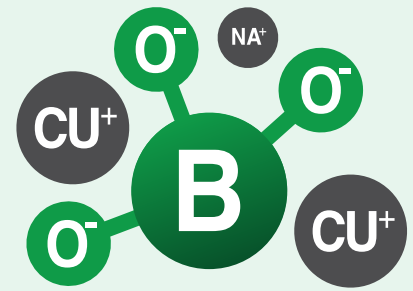

- Individually both copper and boron are recognized and proven biocides.
- Various studies show that borates prevent the growth of the Basidiomycetes family of fungi (Brown and White) very well; however, copper prevents the growth of the Ascomycetes family of fungi (soft rot). It has been widely documented that .82kg/m<sup>3</sup> (minimum load rate) of boron will control decay fungi effectively (brown and white rot).
- The effective toxic threshold for boron is .82kg/m<sup>3</sup>
- When loaded according to the load table (Figure 1), the Cobra™ Rod delivers boron retentions in excess of these required toxic thresholds.

## Family tree of some fungi involved in wood decay.

By Dr P I Morris (Imperial College London) and B Calver (Eastern Electricity Board)

### COPPER BETTER

### BORON BETTER

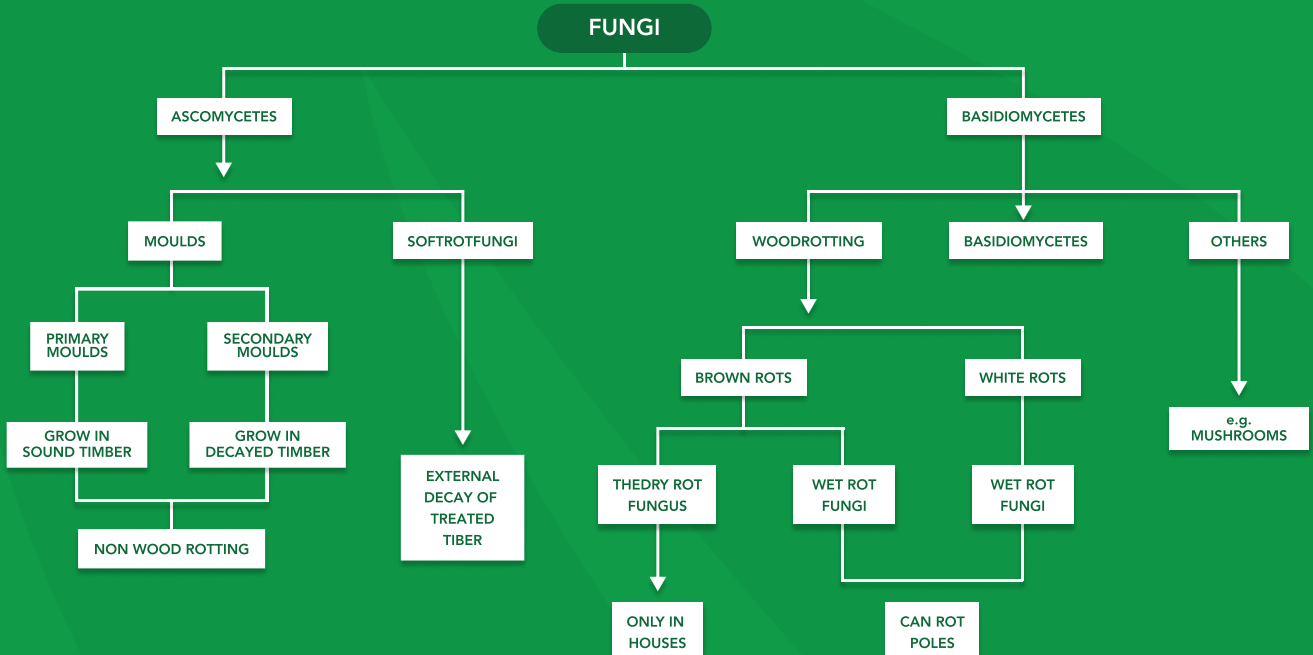

## Cobra™ Rods – Concentration and Solubility

### TOTAL SOLUBILITY (at 20°C): 21.3%

One metric used to determine the overall uptake or bioavailability of active ingredients is to assess the solubility of the products, which determines how much of the active ingredients are absorbed into the wood cells and fibers. In limited moisture environments, such as utility poles, higher solubility facilitates improved dispersion and migration, maximizing the efficacy of the preservative.

Cobra™ Rods offer double the solubility of all other diffusible internal remedial treatments. The solubility of boron on its own is 9.7%. When fused with copper, the system's total solubility increases to 21.3%. This results in significantly increased volume of actives made available to the wood. The Cobra™ Rod manufacturing process dehydrates the DOT and Copper Hydroxide in the production of glass, producing an affinity for moisture; therefore, once introduced to moisture within the pole, the copper and boron bind with the water molecules to travel throughout the wood. As per the U.S.D.A. Forest Products Labs, wood becomes susceptible to decay between 20-30% moisture content, the same range at which the Cobra™ Rod begins to dissolve.

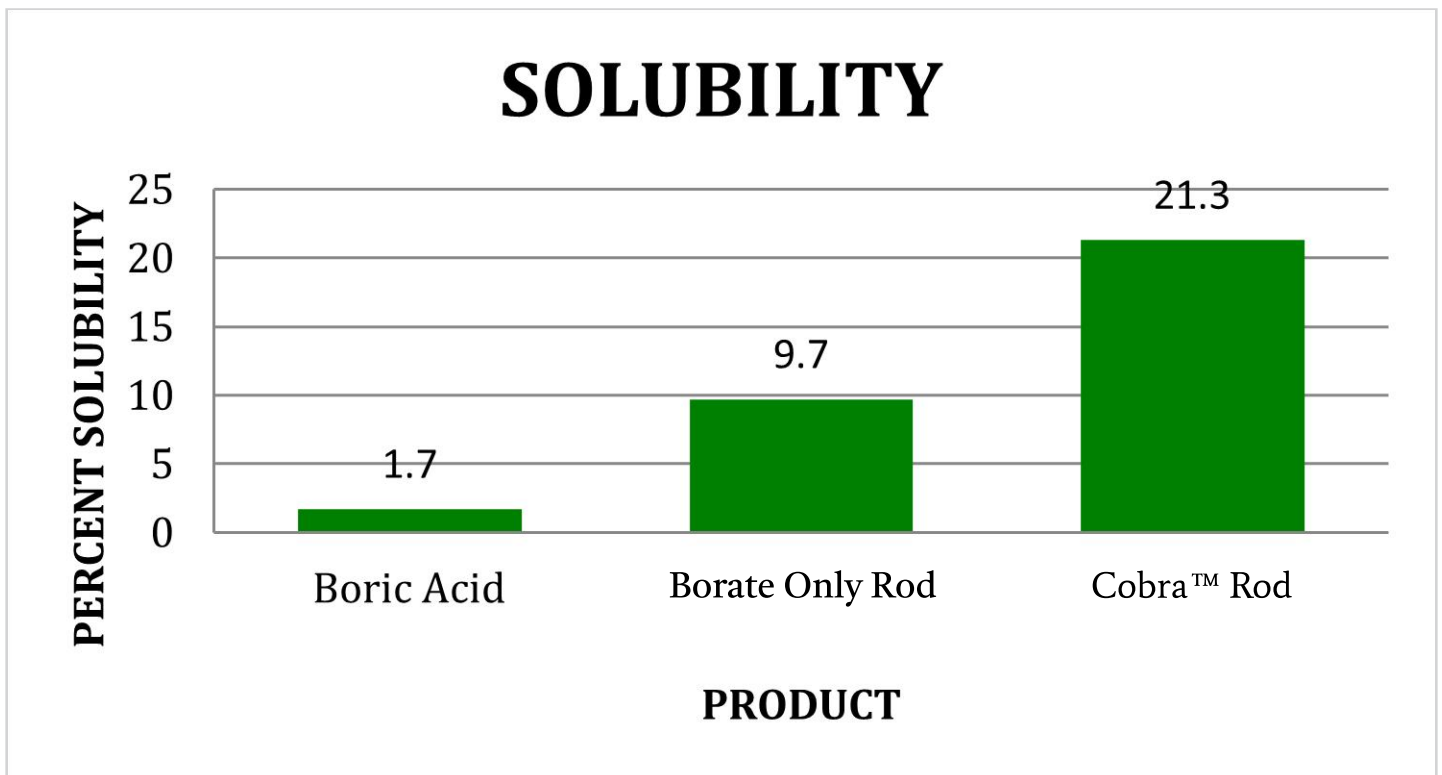

27g of Cobra™ Rod will dissolve in 100 ml of solution (water) at room temperature, while only 10.7g of traditional boron rods and 1.7g of non-dehydrated boric acids will dissolve in the same volume of water.

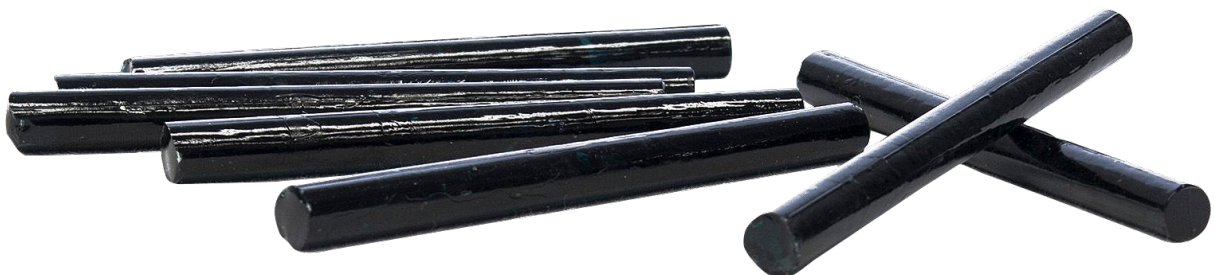

# Cobra™ Rods – Toxicity and Environmental

## Active Ingredient ORAL Lethal Dose 50 (LD50)

- Disodium Octaborate Tetrahydrate: 2550 mg/kg
- Copper Hydroxide: 878 mg/kg
- Boric Acid: 3450 mg/kg
- Table Salt: 3000 mg/kg – Reference Figure 4

Lethal Dose 50 is the amount of a material, given all at once, which causes the death of 50% of a group of test animals. LD50 is a highly effective method of measuring the toxicity of a material. The larger the number, the safer the compound. A critical part of a strong asset management program is to reduce the risks associated with potential exposure of toxic compounds to humans and the surrounding environment. The Cobra™ Rod has a very favorable environmental and toxicity profile due to its composition of using safe and effective active ingredients. The LD50 of table salt is included as a reference point for the overall understanding of the LD50 numbers.

**Copper Hydroxide:** Essential micro-nutrient for plants and listed by the Organic Materials Review Institute for use on organic farms.

**Disodium Octaborate Tetrahydrate:** Essential micro-nutrient for plants and listed by the Organic Materials Review Institute for use on organic farms.

**Boric Acid:** Essential micro-nutrient for plants and listed by the Organic Materials Review Institute for use on organic farms.

## Lethal Dose 50 Comparison (Rat Oral Toxicity)

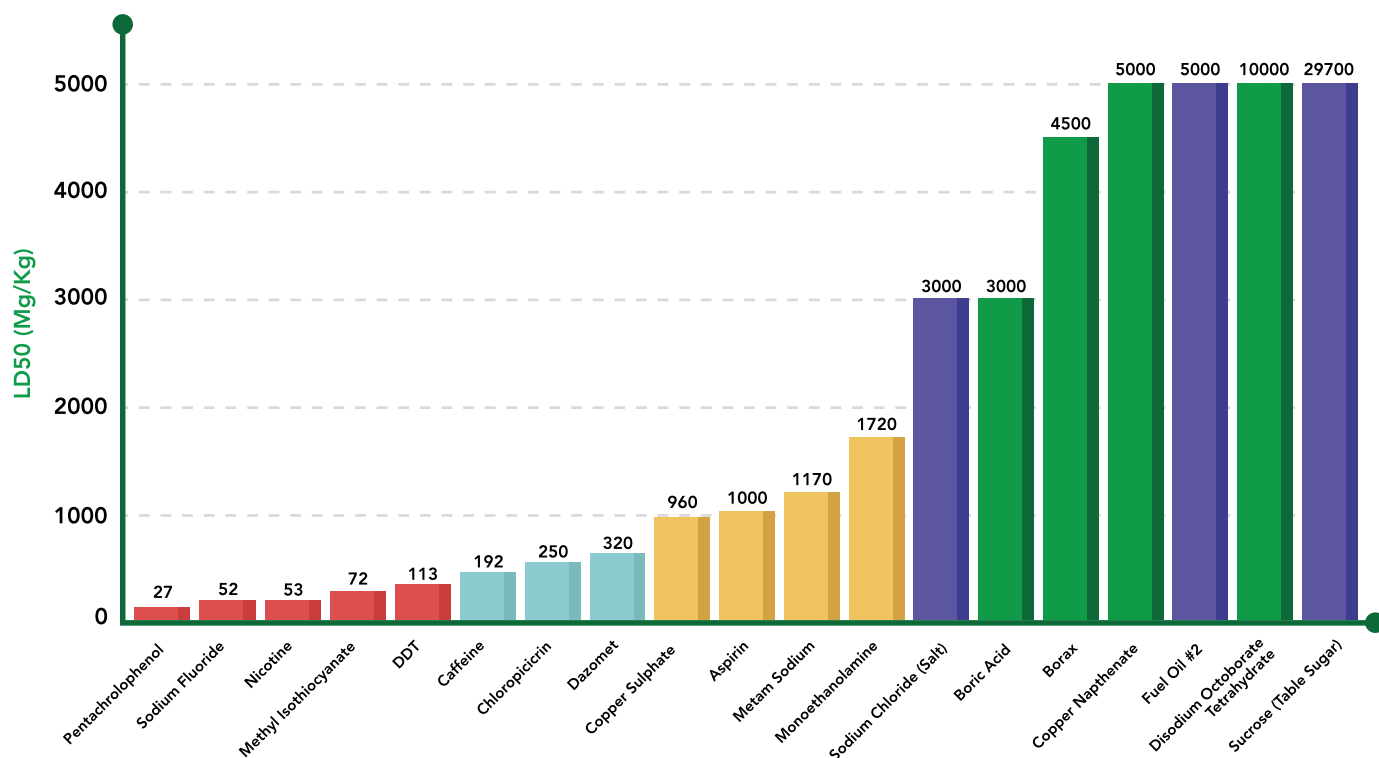

Lethal Dose 50 (LD50): The lethal dose of an ingested substance that kills 50 percent of a test sample. LD50 is typically expressed in mg/kg, or milligrams per kilogram of body weight.

In summary, the positive environmental and safety profile of the Cobra™ Rod poses minimal threat to utilities, installers, communities, wildlife, and the environment.

# Cobra™ Rods – Performance Summary

Genics has conducted research and testing with the following research institutions:

- FPInnovations
- Mississippi State University
- Innotech Alberta
- Louisiana State University
- Oregon State University
- Powertech Laboratories
- University of Toronto
- University of Hawaii



## Full Reports Available Upon Request.

**10-Year Hilo Study:** Cobra™ Rods demonstrate above threshold levels for copper and boron after 10 years in the aggressive decay climate and zone of Hilo, Hawaii.

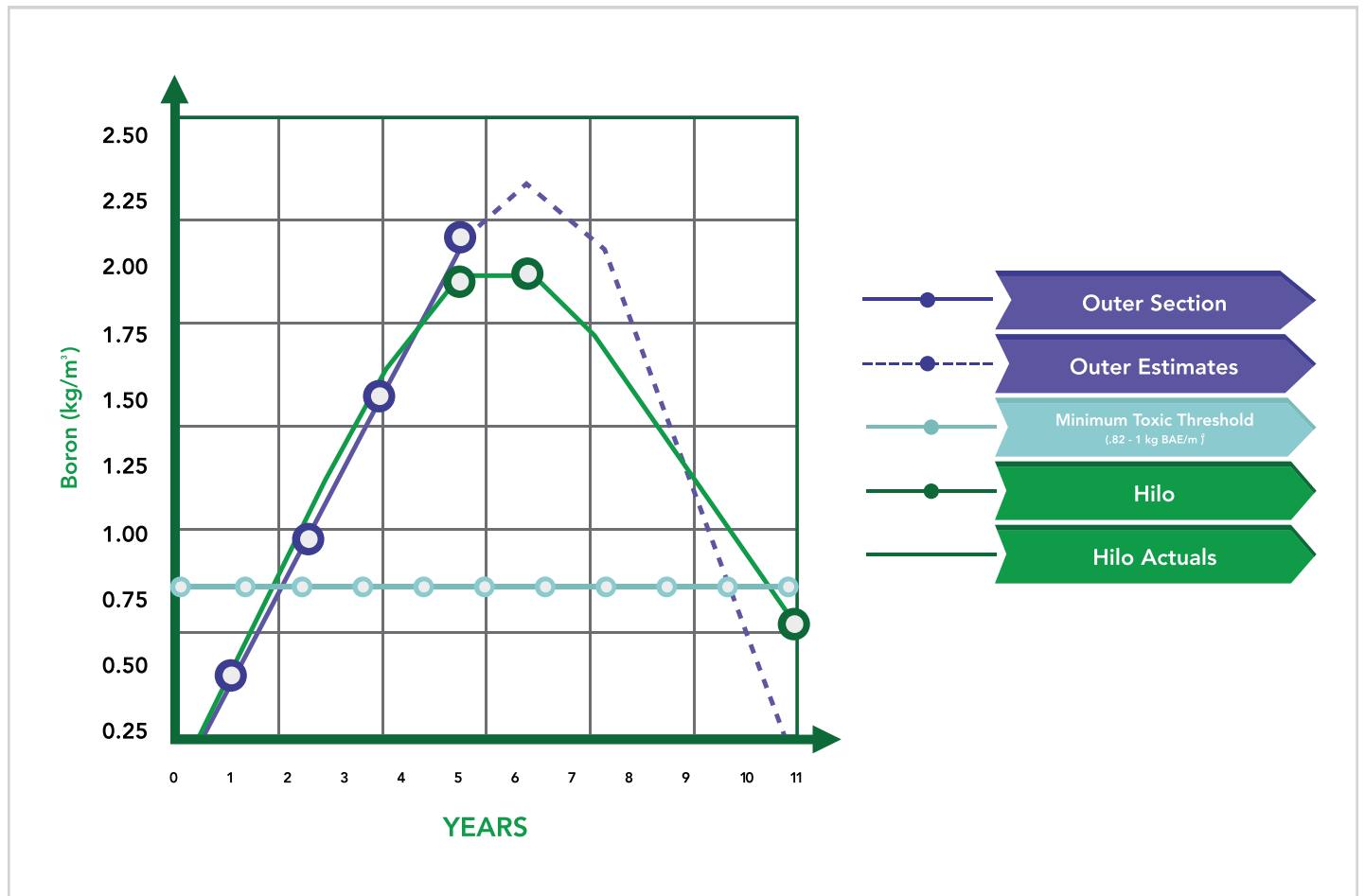

10-Year study of Cobra™ Rods demonstrates toxic threshold retention levels for all poles treated with Cobra™ Rods. Hilo is classified as a decay zone 3 as per current AWPA standards (formerly decay zone 5).

## Powertech Labs

The results of the literature search indicates that the boron/copper formulation of the Cobra™ Rod will have a number of advantages over the 100% boron rod. Fungal efficacy will be increased due to the synergistic effect of boron and copper in that the boron would offer protection against internal attack of treated wood from copper tolerant basidiomycetes and insects; whereas, the copper would protect the outer surfaces of the wood against attack by boron tolerant soft-rot fungi.

The fusion of the boron and copper into copper borate, rather than a simple admixture of the compounds, is also beneficial in that it enhances the mobility of copper within the wood and at the same time retards the mobility of some of the boron. This will extend the fungal efficacy longevity of the preservative treatment, which is a shortcoming of the 100% boron rod, especially in wetter climatic areas, both by delaying the loss of boron from the treated wood and by the presence of copper in the wood long after the boron as eventually been depleted.

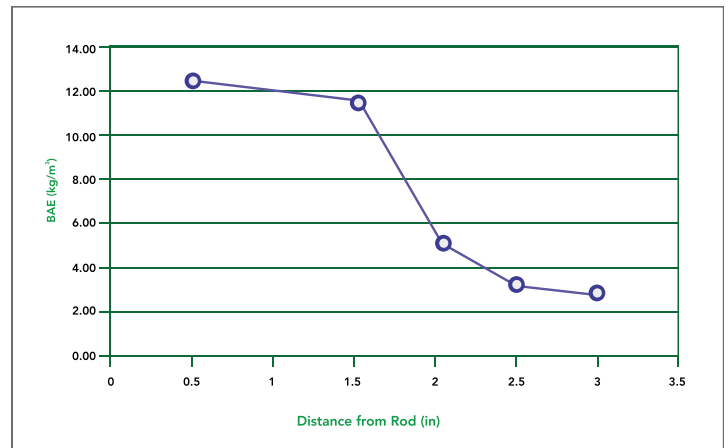

Boron Concentration as a Function of Distance from Cobra™ Rod Location

## Cobra™ Rods – Installation Instructions

- Use the appropriate diameter drill bit to accommodate the appropriate size of Cobra™ Rods you wish to use. Drill to a depth deep enough to accommodate specified number of rods per hole, while taking into account the length of the Cobra™ Plug.
- Insert suitable size and number of Cobra™ Rod(s) one at a time to assure adequate preservative loading (reference Figure 6 below)
- Seal the treatment holes with Cobra™ Plug. The Cobra™ Plug should be 1/16" larger in diameter than the treatment hole.
- Cobra™ Plug can be removed and reused in subsequent treatment cycles.

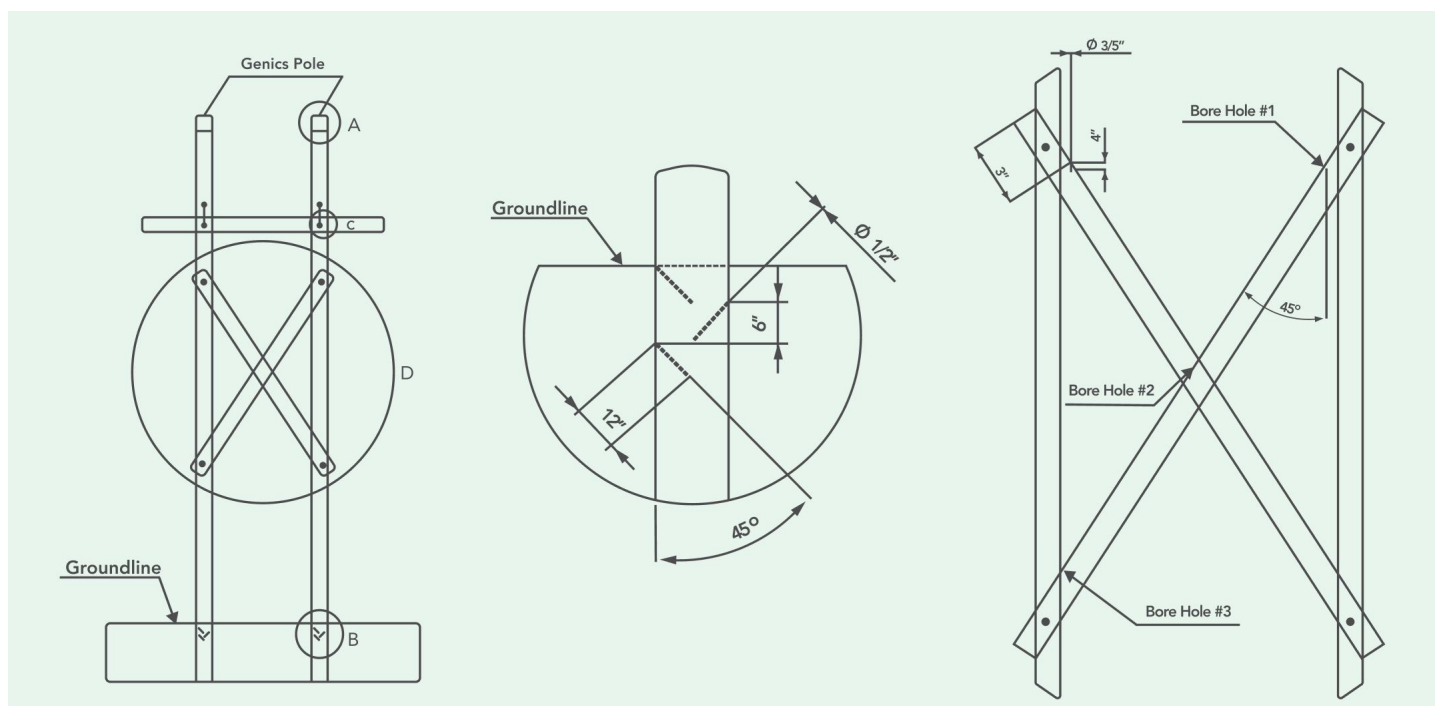

# Recommended Cobra Road Loading Tables

Cobra Rod Load Rate ( 2 kg/m <sup>2</sup> )				
Pole Circumference	Number of Cobra Rods	Boring Diameter	Boring Depth (inches)	Number of Borings
<27	2	1/2"	6.00	3
28-30	2	1/2"	6.00	3
31-33	2	1/2"	8.00	3
33-35	2	1/2"	8.00	3
36-38	2	1/2"	8.00	3
39-41	2	1/2"	8.00	3
42-44	3	1/2"	10.00	3
45-47	4	1/2"	10.00	3
48-50	4	1/2"	10.00	3
51-53	5	1/2"	12.00	3
54-56	6	1/2"	12.00	4
57-59	7	1/2"	12.00	4
60-62	7	1/2"	16.00	4
63-65	8	1/2"	16.00	4
66-75	11	1/2"	18.00	5
76-84	14	1/2"	18.00	5
85-94	18	1/2"	18.00	6
95-100	20	1/2"	18.00	6
100+	24	1/2"	18.00	8



Cobra Rod Load Rate ( 6 kg/m <sup>2</sup> )				
Pole Circumference	Number of 3/4" x 3" Cobra Rods	Boring Diameter	Boring Depth (inches)	Number of Borings
<27	2	3/4"	6.00	2
28-30	2	3/4"	6.00	2
31-33	2	3/4"	6.00	2
33-35	3	3/4"	8.00	2
36-38	3	3/4"	8.00	2
39-41	4	3/4"	8.00	2
42-44	4	3/4"	8.00	2
45-47	5	3/4"	8.00	2
48-50	6	3/4"	8.00	3
51-53	6	3/4"	8.00	3
54-56	7	3/4"	12.00	3
57-59	8	3/4"	12.00	3
60-62	9	3/4"	12.00	3
63-65	10	3/4"	18.00	4
66-75	13	3/4"	18.00	4
76-84	17	3/4"	18.00	4
85-94	21	3/4"	18.00	5
95-100	24	3/4"	18.00	6
100+	30	3/4"	18.00	6



Ensure the use of proper PPE as per the label, SDS sheet, State guidelines.

This product is manufactured in an ISO 14001 facility.

